



Counterflow plate heat recovery exchanger



BASIC FEATURES

WHISPER AIR

Highly efficient wall mounted heat recovery unit designed for ductless installations and decentralised ventilation of **classrooms, offices, conference rooms, family houses.**

- **3 sizes with air flow: 400, 700 and 1000 m³/h**
- Ecodesign directive 1253/2014 compliant
- Heat recovery efficiency up to 93% (EN308) with **sensible** counterflow aluminium exchanger
- Humidity recovery up to 85% (EN308) with **enthalpy** counteflow plastic exchanger
- Silent operation with only **35dB(A)** at nominal airflow
- Straw-System for optimised and laminar airflow
- Energy-efficient EC fans with low SFP
- Slim design with low installation height for efficient space usage
- Choice of **horizontal** version (horizontal connections for supply and exhaust) and **upper** versions (horizontal top connections for supply and exhaust)
- Sandwich panel casing with thermal insulation 40mm
- Boost function (+25% over nominal airflow)
- Integrated pre-heater (electric) / post-heater (electric, water or change/over)
- **AirGENIO Superior** control system with an option of CAV or DCV mode, supplementary modes (timer, anti-freeze protection, etc.), integrated CO₂ sensor, touch-screen control panel, BMS control via ModBUS RTU, Modbus TCP or BACnet.

WHISPER AIR heat recovery unit is designed to be operated in a dry indoor environment (relative humidity not exceeding 80%) and at an ambient temperature in the range from +5°C up to +60°C.

The unit is designed for transporting standard atmospheric air that is free of dust, grease, chemical emissions and other impurities. The transported air relative humidity must not exceed 90%.

The casing of the unit is made from sandwich panels. When unit installed its IP rating is 20.

The design of the ventilation project must be **always designed by a qualified HVAC designer, engineer or architect.**

MAIN PARTS

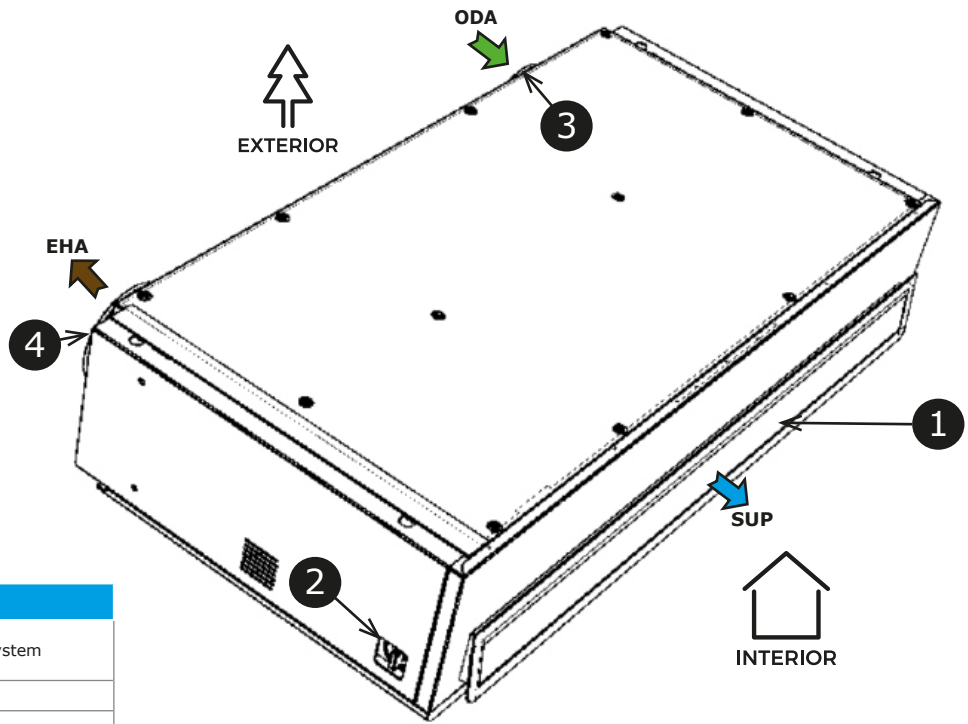

	EN
1	Outlet grill with Straw system
2	Main switch
3	Outside fresh air duct with spring loaded damper
4	Outside exhaust air duct with spring loaded damper
5	Inlet grill with Straw system
6	Condensate drain

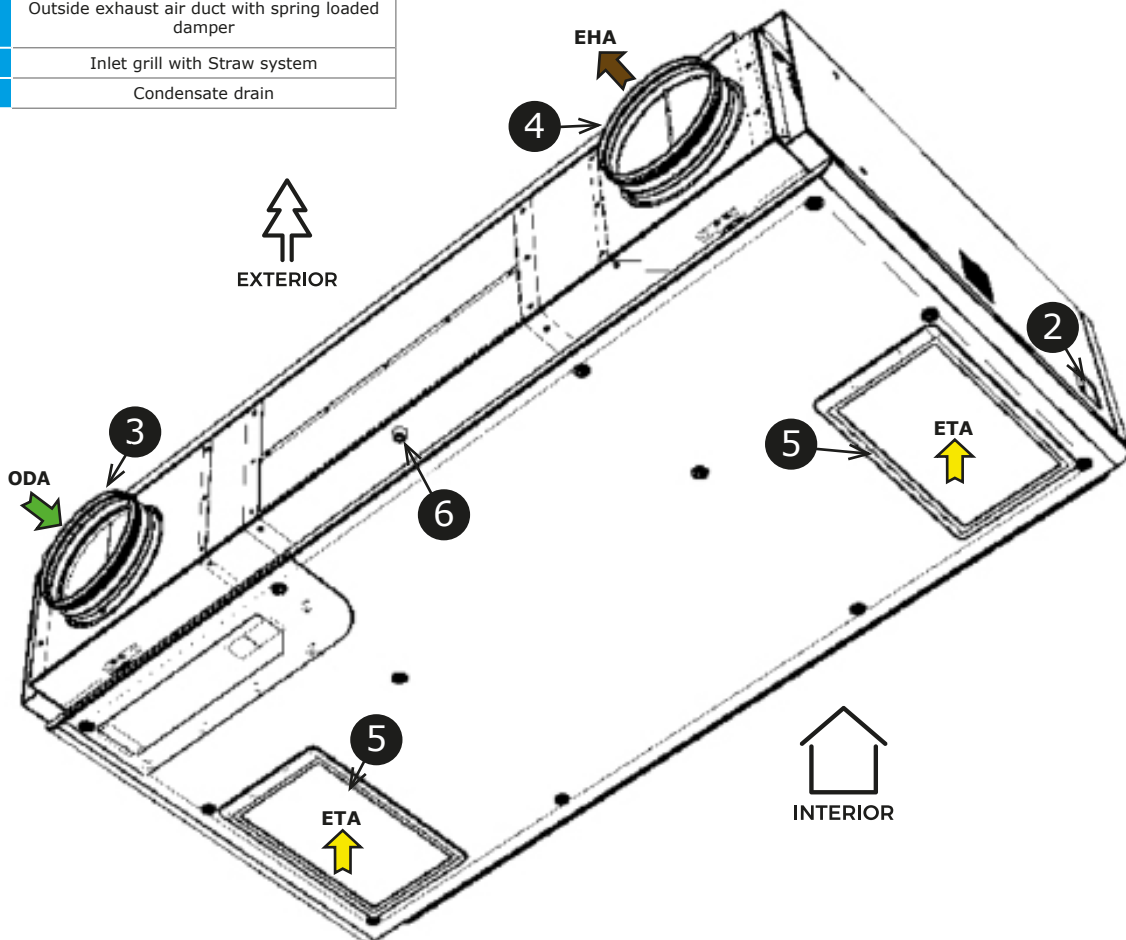

Operational diagram

	EN
1	Fan
2	Filter
3	Preheater
4	Afterheater
5	Condensate drain
6	Heat exchanger with by-pass damper
7	Straw-System

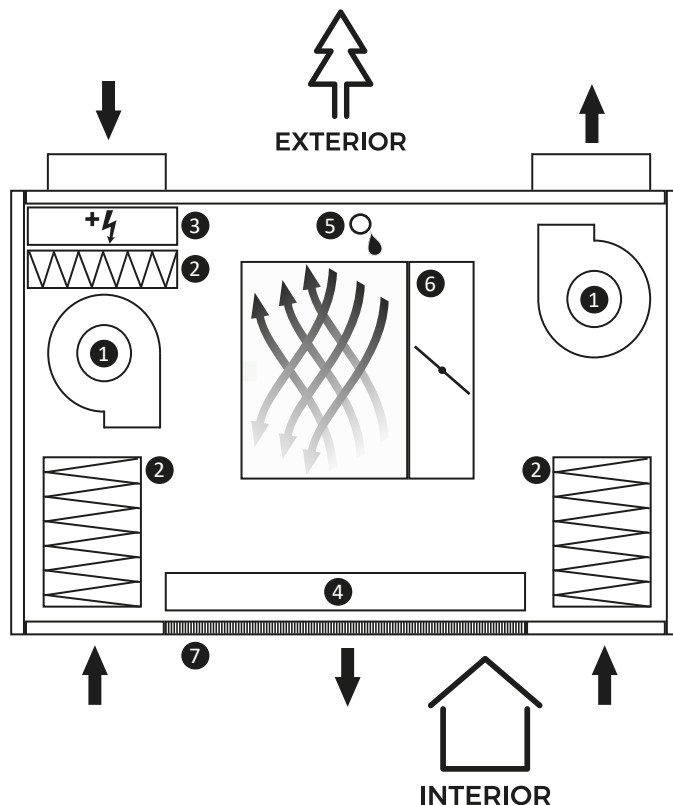

PRIMARY PARAMETERS

SFP=Unit Power input/supply airflow (kW/m³/s)

HRWA 400

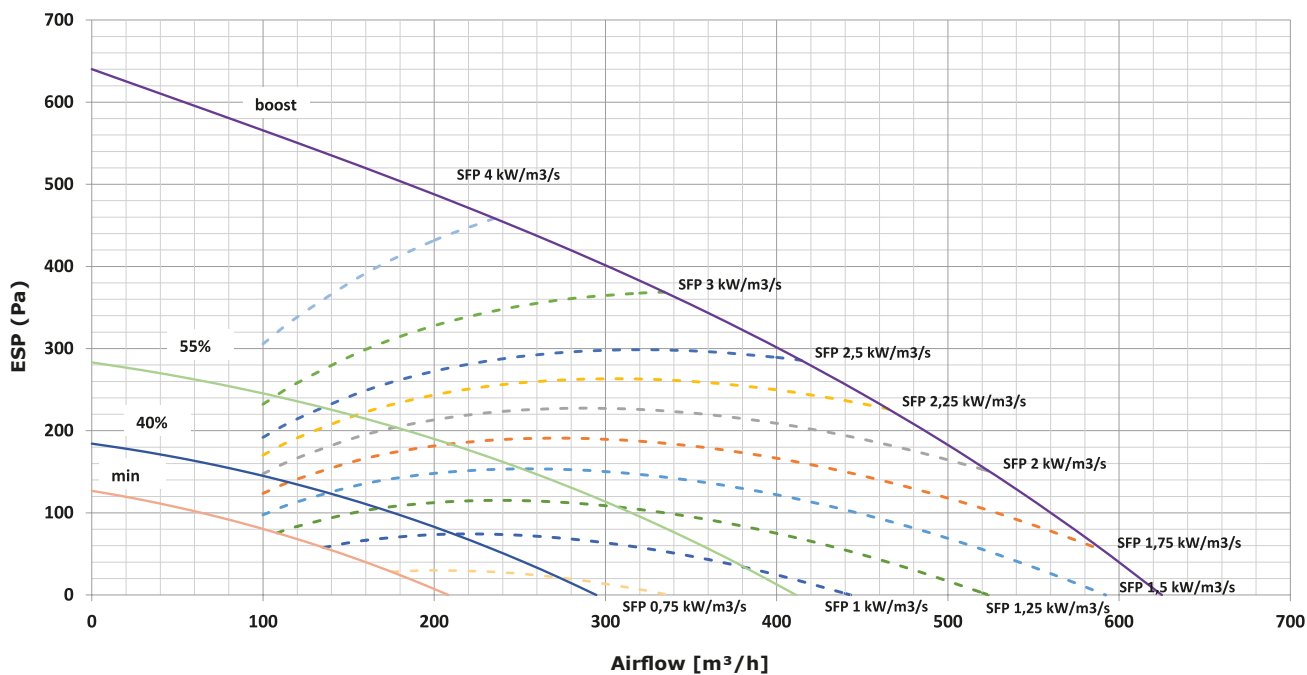

HRWA 700

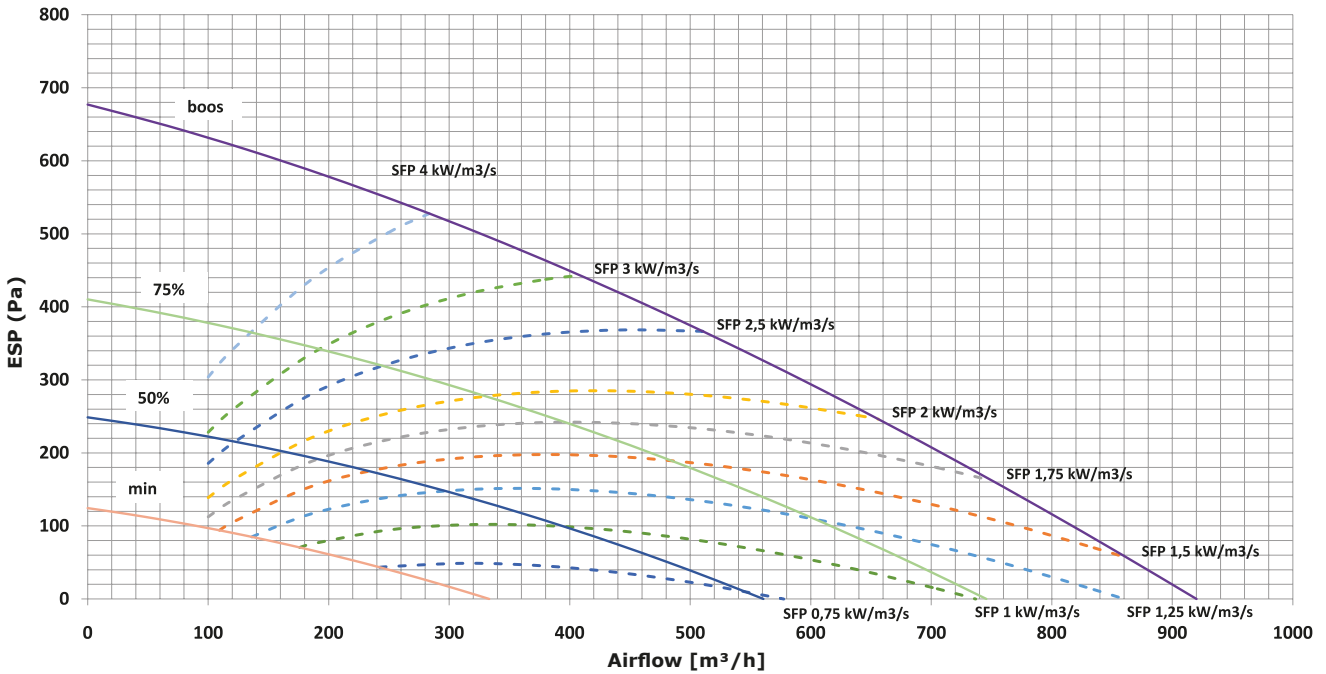

HRWA 1000

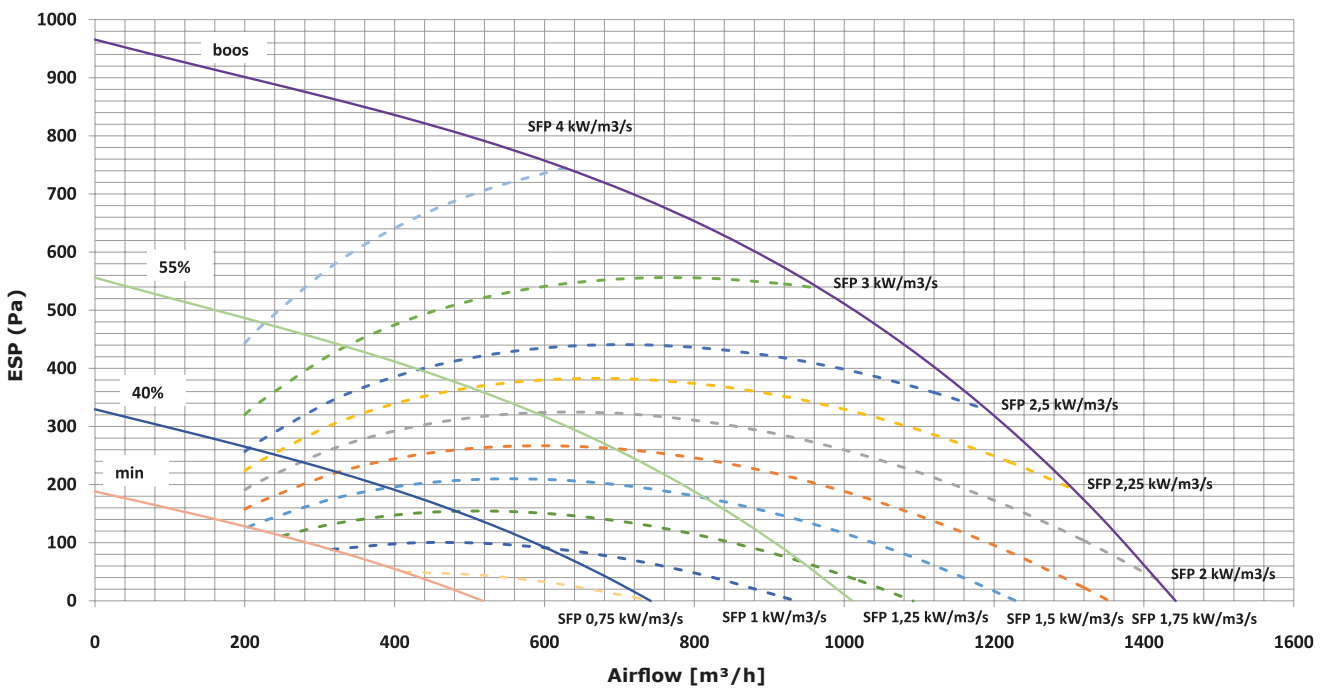



PRIMARY PARAMETERS

Heat recovery efficiency:

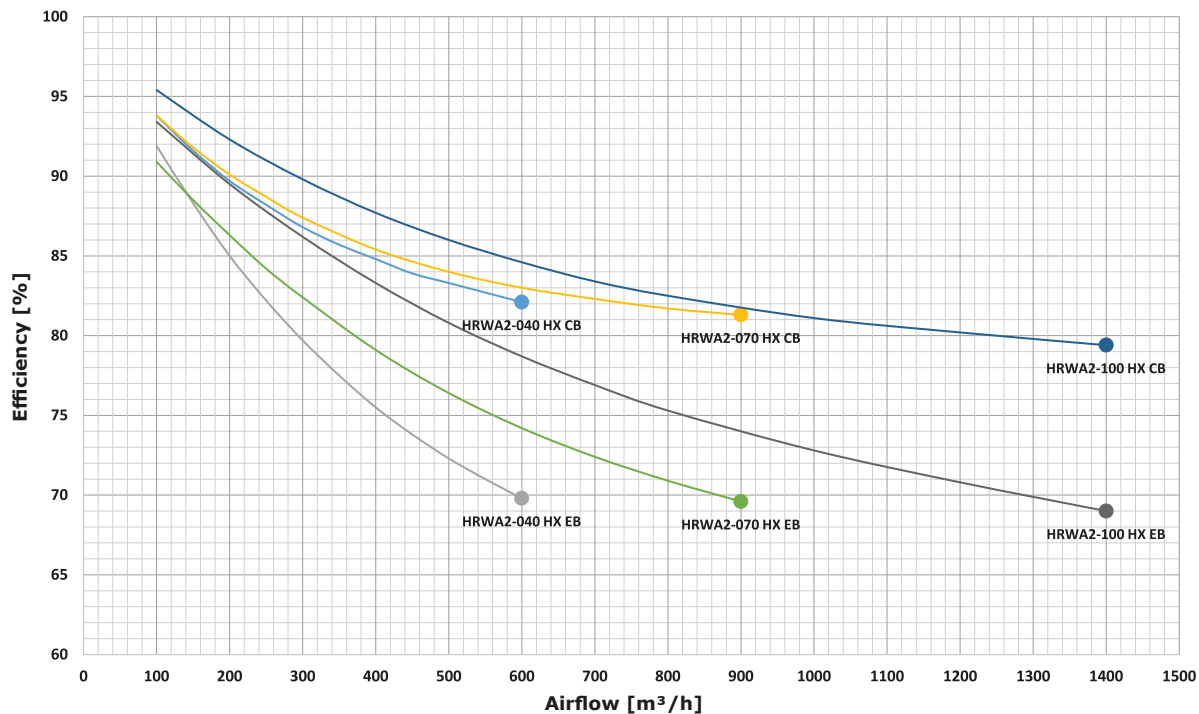

The data is measured under following conditions (EN308):
 Outdoor air temperature is +5°C, relative humidity 72%
 Indoor air temperature is +25°C, relative humidity 28%

Humidity recovery efficiency:

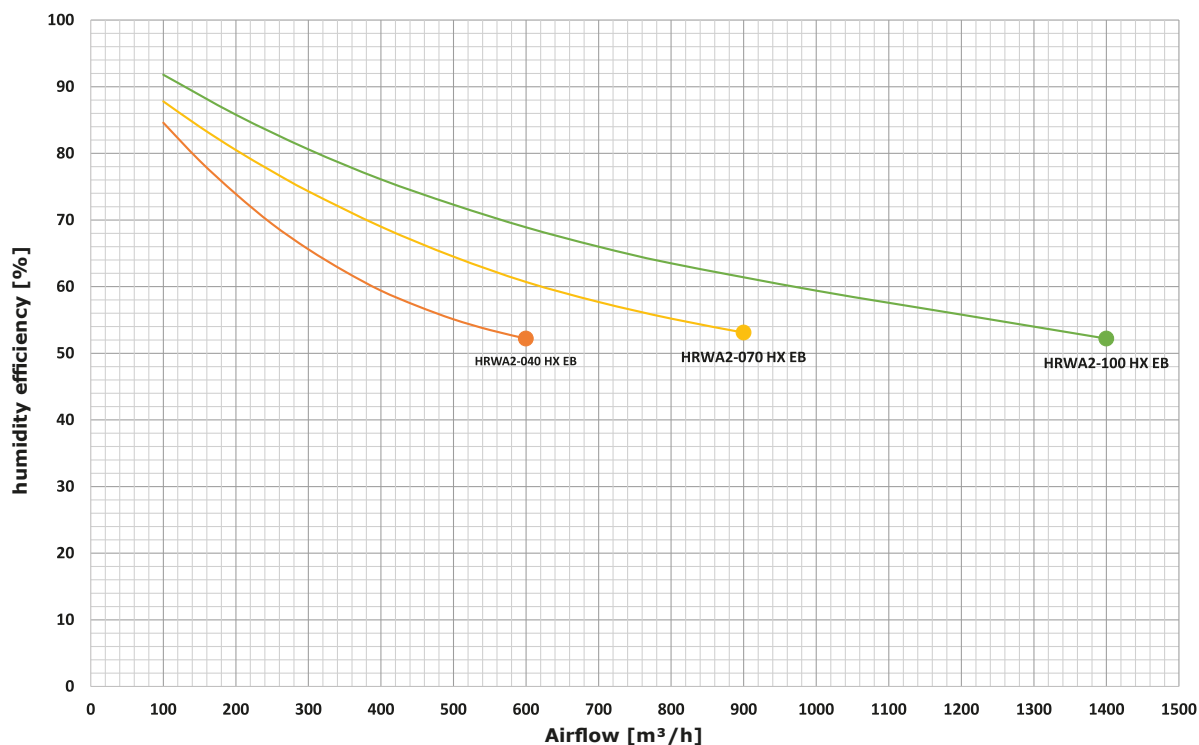

The data is measured under following conditions (EN308):
 Outdoor air temperature is +5°C, relative humidity 72%
 Indoor air temperature is +25°C, relative humidity 28%

Air Reach:

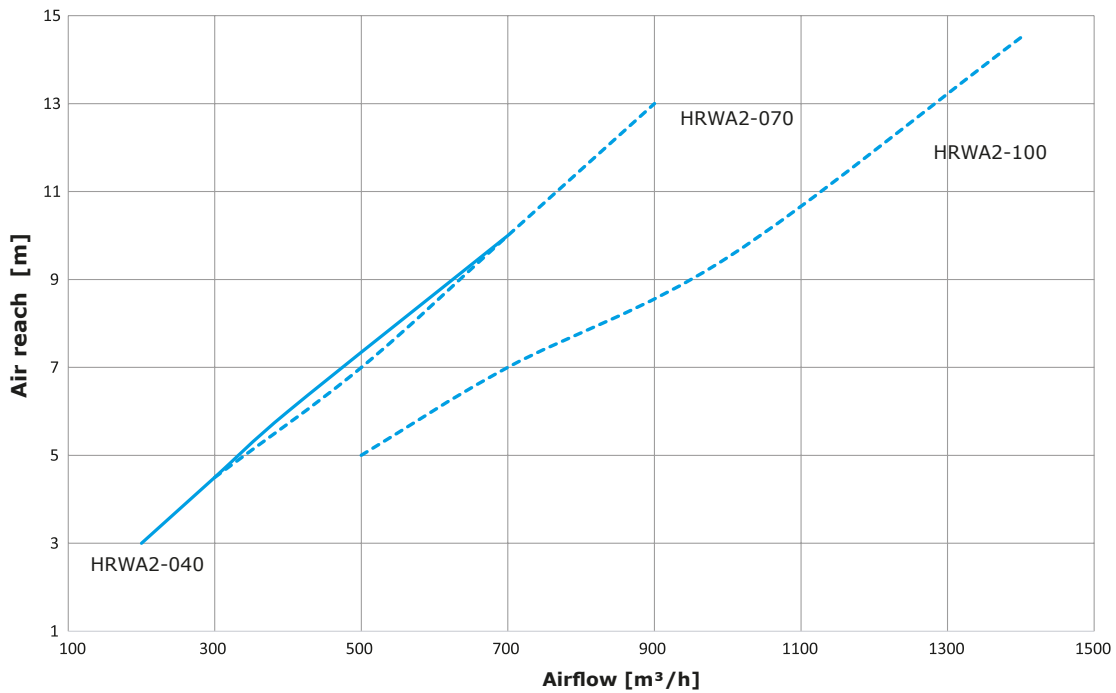

PRIMARY PARAMETERS

Noise specifications:

HRWA2-040 (casing radiated sound power level)

Fan speed	Pressure [Pa]	Airflow [m³/h]	Sound power level per frequency band								Overall		
			63Hz	125Hz	250Hz	500Hz	1kHz	2kHz	4kHz	8kHz	L _{WA} [dB]	L _{PA} [dB] ¹⁾	L _{PA} [dB] ²⁾
min	0	169	28,8	38,4	31,3	27,4	26,9	25,5	26,5	25,0	40,5	27,8	21,2
mid (40%)	0	316	31,8	40,2	38,7	33,0	31,0	27,0	24,7	24,8	43,7	31,0	24,4
nominal (55%)	0	415	35,9	43,0	43,9	37,3	34,7	29,9	25,7	25,2	47,7	34,9	28,3
Boost (100%)	0	625	45,4	52,0	54,1	47,2	43,9	40,5	32,3	28,4	57,3	44,6	38,0

- 1) Sound pressure levels calculated at 1 meter for Q=4
- 2) Sound pressure levels calculated at 3 meters for Q=4

HRWA2-040 (sound power level in exhaust air duct)

Fan speed	Pressure [Pa]	Airflow [m³/h]	Sound power level per frequency band								Overall
			63Hz	125Hz	250Hz	500Hz	1kHz	2kHz	4kHz	8kHz	L _{WA} [dB]
min	0	169	35,5	37,9	40,2	30,8	24,1	19,8	15,0	15,7	43,4
mid (40%)	0	316	40,5	46,0	50,6	41,7	37,8	38,0	29,8	26,3	52,9
nominal (55%)	0	415	43,9	49,8	56,5	48,4	44,9	46,7	37,7	33,8	58,6
Boost (100%)	0	625	53,8	57,3	64,0	57,6	54,7	57,8	53,5	52,5	67,1

HRWA2-040 (sound power level in fresh air duct)

Fan speed	Pressure [Pa]	Airflow [m³/h]	Sound power level per frequency band								Overall
			63Hz	125Hz	250Hz	500Hz	1kHz	2kHz	4kHz	8kHz	L _{WA} [dB]
min	0	169	37,4	38,0	39,2	28,4	26,5	17,2	15,3	13,6	43,3
mid (40%)	0	316	42,9	46,4	50,4	39,5	40,2	34,4	30,2	21,3	52,9
nominal (55%)	0	415	45,7	49,6	55,3	44,9	45,9	41,8	37,7	27,1	57,5
Boost (100%)	0	625	54,2	54,8	60,0	50,7	53,6	51,5	51,7	43,9	63,5

HRWA2-070 (casing radiated sound power level)

Fan speed	Pressure [Pa]	Airflow [m³/h]	Sound power level per frequency band								Overall		
			63Hz	125Hz	250Hz	500Hz	1kHz	2kHz	4kHz	8kHz	L _{WA} [dB]	L _{PA} [dB] ¹⁾	L _{PA} [dB] ²⁾
min	0	307	20,1	32,6	35,3	29,5	22,5	22,0	28,1	27,0	38,8	25,6	19,3
mid (40%)	0	561	33,3	37,1	36,1	32,1	31,5	29,2	27,4	25,8	42,1	28,8	22,5
nominal (55%)	0	747	39,0	41,8	43,6	39,2	38,7	35,8	29,2	26,5	48,3	35,0	28,7
Boost (100%)	0	916	44,0	48,8	51,1	46,2	44,7	42,3	33,6	27,6	55,1	41,8	35,5

- 1) Sound pressure levels calculated at 1 meter for Q=4
- 2) Sound pressure levels calculated at 3 meters for Q=4

HRWA2-070 (sound power level in exhaust air duct)

Fan speed	Pressure [Pa]	Airflow [m³/h]	Sound power level per frequency band								Overall
			63Hz	125Hz	250Hz	500Hz	1kHz	2kHz	4kHz	8kHz	L _{WA} [dB]
min	0	307	32,4	39,7	39,9	33,0	28,2	27,0	24,1	22,9	43,9
mid (40%)	0	561	38,6	46,9	52,9	44,1	41,3	44,3	36,8	34,1	55,1
nominal (55%)	0	747	44,2	51,5	59,0	50,9	48,2	51,9	45,1	43,0	61,4
Boost (100%)	0	917	49,7	58,2	63,5	56,5	53,1	56,9	54,2	53,2	66,6

HRWA2-070 (sound power level in fresh air duct)

Fan speed	Pressure [Pa]	Airflow [m³/h]	Sound power level per frequency band								Overall
			63Hz	125Hz	250Hz	500Hz	1kHz	2kHz	4kHz	8kHz	L _{WA} [dB]
min	0	307	34,7	39,9	37,4	34,6	33,0	26,1	23,2	20,7	43,8
mid (40%)	0	561	38,8	45,7	48,5	43,4	44,0	42,3	35,4	29,3	52,7
nominal (55%)	0	747	43,5	48,9	54,0	47,9	49,5	48,6	43,2	37,0	57,8
Boost (100%)	0	917	49,0	54,0	57,1	51,9	54,1	52,1	51,6	45,9	62,0

HRWA2-100 (casing radiated sound power level)

Fan speed	Pressure [Pa]	Airflow [m³/h]	Sound power level per frequency band								Overall		
			63Hz	125Hz	250Hz	500Hz	1kHz	2kHz	4kHz	8kHz	L _{WA} [dB]	L _{PA} [dB] ¹⁾	L _{PA} [dB] ²⁾
min	0	499	24,1	37,5	30,0	26,7	25,5	20,3	13,5	11,5	38,9	25,0	19,0
mid (40%)	0	772	29,3	38,6	37,4	33,7	34,2	28,7	23,1	21,0	43,0	29,0	23,0
nominal (55%)	0	1018	39,2	42,6	43,8	39,9	40,3	35,8	30,7	27,0	48,8	34,9	28,9
Boost (100%)	0	1456	47,7	53,6	54,0	56,3	53,5	51,6	45,5	34,2	61,4	47,4	41,5

- 1) Sound pressure levels calculated at 1 meter for Q=4
- 2) Sound pressure levels calculated at 3 meters for Q=4

HRWA2-100 (sound power level in exhaust air duct)

Fan speed	Pressure [Pa]	Airflow [m³/h]	Sound power level per frequency band								Overall
			63Hz	125Hz	250Hz	500Hz	1kHz	2kHz	4kHz	8kHz	L _{WA} [dB]
min	0	499	36,9	38,0	37,2	32,9	37,6	30,2	28,8	28,7	44,3
mid (40%)	0	772	40,7	43,8	46,8	40,5	45,8	42,2	39,5	37,2	52,1
nominal (55%)	0	1018	44,5	47,5	52,5	46,7	51,9	50,7	46,9	44,2	58,2
Boost (100%)	0	1456	52,4	52,3	54,4	59,2	62,6	62,2	57,1	57,7	67,8

HRWA2-100 (sound power level in fresh air duct)

Fan speed	Pressure [Pa]	Airflow [m³/h]	Sound power level per frequency band								Overall
			63Hz	125Hz	250Hz	500Hz	1kHz	2kHz	4kHz	8kHz	L _{WA} [dB]
min	0	499	33,4	37,7	43,9	37,0	33,5	32,5	30,2	32,8	46,5
mid (40%)	0	772	39,5	44,6	51,6	44,3	44,2	46,1	42,8	44,2	55,1
nominal (55%)	0	1018	45,3	50,3	57,0	50,3	52,0	55,6	51,9	52,6	62,1
Boost (100%)	0	1456	56,1	59,2	62,5	63,7	62,6	67,5	64,2	62,9	72,4

Basic technical parameters of the heat recovery units:

Model without preheater and afterheater

Type	Phase [pcs]	Voltage [V]	Frequency [Hz]	Total consumption [W]	Total current [A]	Weight [kg]*	Weight [kg]* Top connection
HRWA2-040..-XS0...	1	230	50	350	2,45	92/82*	98/88*
HRWA2-070..-XS0...	1	230	50	350	2,45	126/116*	133/123*
HRWA2-100..-XS0...	1	230	50	800	4,85	149/139*	158/148*

* Weight of STANDARD cover



Attention:

Models without preheater are suitable for outside air not lower than -5°C. In situations lower than -5°C unit will work in antifreeze mode and could shut down to prevent damage of internal components. We recommend installation should be designed by an HVAC professional.

Model with electric preheater only

Type	Phase [pcs]	Voltage [V]	Frequency [Hz]	Total consumption [W]	Total current [A]	Weight [kg]	Weight [kg] Top connection
HRWA2-040..-ES0...	1	230	50	1850	8,98	93/83*	99/89*
HRWA2-070..-ES0...	1	230	50	2600	12,24	127/117*	134/124*
HRWA2-100..-ES0...	3	400	50	3800	7,5	150/140*	159/149*

* Weight of STANDARD cover

Model with electric afterheater only

Type	Phase [pcs]	Voltage [V]	Frequency [Hz]	Total consumption [W]	Total current [A]	Weight [kg]	Weight [kg] Top connection
HRWA2-040..-XE1...	1	230	50	1850	8,98	93/83*	99/89*
HRWA2-070..-XE1...	1	230	50	2350	11,15	127/117*	134/124*
HRWA2-100..-XE1...	3	400	50	3800	9,18	150/140*	159/149*
HRWA2-100..-XE0...	1	230	50	2800	13,7	150/140*	159/149*

* Weight of STANDARD cover

Model with water afterheater only

Type	Phase [pcs]	Voltage [V]	Frequency [Hz]	Total consumption [W]	Total current [A]	Weight [kg]	Weight [kg] Top connection
HRWA2-040..-XV1...	1	230	50	350	2,45	93/83*	99/89*
HRWA2-070..-XV1...	1	230	50	350	2,45	127/117*	134/124*
HRWA2-100..-XV1...	1	230	50	800	4,85	150/140*	159/149*

* Weight of STANDARD cover

Model with electric preheater and electric afterheater

Type	Phase [pcs]	Voltage [V]	Frequency [Hz]	Total consumption [W]	Total current [A]	Weight [kg]	Weight [kg] Top connection
HRWA2-040..-EE1...	1	230	50	3350	15,51	94/84*	100/90*
HRWA2-070..-EE1...	3	400	50	4600	9,79	128/118*	135/125*
HRWA2-100..-EE1...	3	400	50	6800	11,83	151/141*	160/150*

* Weight of STANDARD cover

Model with electric preheater and water afterheater

Type	Phase [pcs]	Voltage [V]	Frequency [Hz]	Total consumption [W]	Total current [A]	Weight [kg]	Weight [kg] Top connection
HRWA2-040..-EV1...	1	230	50	1850	8,98	96/86*	102/92*
HRWA2-070..-EV1...	1	230	50	2350	11,15	130/120*	137/127*
HRWA2-100..-EV1...	3	400	50	3800	7,5	153/143*	162/152*

* Weight of STANDARD cover

Characteristics of electric motor (1 fan only)

Type	Phase [pcs]	Voltage [V]	Frequency [Hz]	Total consumption [W]	Total current [A]	Speed [r/min]	Protection IP	Insulation class
HRWA2-040	1	230	50	170	1,20	2550	54	B
HRWA2-070	1	230	50	170	1,20	2550	54	B
HRWA2-100	1	230	50	385	2,40	2550	54	B

Characteristics of electric preheater

Type	Phase [pcs]	Voltage [V]	Frequency [Hz]	Total consumption [W]	Total current [A]
HRWA2-040	1	230	50	1500	6,53
HRWA2-070	1	230	50	2000	8,70
HRWA2-100	2	400	50	3000	7,50

Characteristics of electric afterheater

Type	Phase [pcs]	Voltage [V]	Frequency [Hz]	Total consumption [W]	Total current [A]
HRWA2-040..-XE1...	1	230	50	1500	6,53
HRWA2-070..-XE1...	1	230	50	2250	9,79
HRWA2-100..-XE1...	3	400	50	3000	4,33
HRWA2-100..-XE0...	1	230	50	2000	8,7

Characteristics of water heating coil

For water temperature gradient 90/70 and inlet air temperature 10°C

Type	Rated input [kW]	Water pressure loss [kPa]	Air pressure loss [Pa]	Water flow [m³/h]	Connection diameter
HRWA2-040	4,61	5,59	7,26	0,2	1/2"
HRWA2-070	6,56	10,3	19,13	0,29	1/2"
HRWA2-100	9,4	4,32	14,42	0,41	1/2"

Recommended K_{vs} for different temperature gradients

Correction coefficients of the powers of the hot water coil*						
Air inlet temperature [°C]	Water temperature gradient					
	90/70	85/65	80/60	75/55	70/50	65/45
0	1,18	1,1	1,01	0,93	0,85	0,76
5	1,09	1,01	0,93	0,84	0,76	0,68
10	1	0,92	0,84	0,76	0,68	0,6
15	0,91	0,83	1,18	0,67	0,59	0,51
20	0,83	0,75	0,67	0,59	0,51	0,43

* To apply to the rated power in the characteristics of the hot water coil.

Characteristics of change-over coil (C/O)

For water temperature gradient 60/40 and inlet air temperature 10°C

Type	Rated input [kW]	Water pressure loss [kPa]	Air pressure loss [Pa]	Water flow [m³/h]	Connection diameter
HRWA2-040	4,28	0,49	19	0,19	3/4
HRWA2-070	6,41	0,98	49	0,28	3/4
HRWA2-100	8,95	0,59	38	0,39	3/4

Correction coefficients of the powers of the hot water coil*				
Air inlet temperature [°C]	Water temperature gradient			
	60/40	55/50	45/40	35/30
0	1,32	1,51	1,21	0,90
5	1,16	1,34	1,05	0,75
10	1,00	1,18	0,89	0,60
15	0,84	1,02	0,74	0,45
20	0,69	0,87	0,59	0,30

* To apply to the rated power in the characteristics of the C/O coil.

For water temperature gradient 7/12 and inlet air temperature 25°C

Type	Rated input [kW]	Water pressure loss [kPa]	Air pressure loss [Pa]	Water flow [m³/h]	Connection diameter
HRWA2-040	2,84	3,34	20	0,49	3/4
HRWA2-070	4,21	6,77	55	0,72	3/4
HRWA2-100	5,66	3,73	42	0,97	3/4

Correction coefficients of the powers of the hot water coil*			
Air inlet temperature [°C]	Water temperature gradient		
	7/12	6/11	5/10
20	0,42	0,52	0,61
25	1,00	1,10	1,19
30	1,69	1,78	1,88

* To apply to the rated power in the characteristics of the C/O coil.



INSTALLATION AND ASSEMBLY

The unit must be installed in such a way that the direction of the air blown corresponds to the direction of air circulation. The unit must be installed so as to give free access for maintenance, service or dismantling. This is to allow access to service flaps and possibility to open them, access to the lid of the control panel, access to the lateral connections and access to the filter cover.

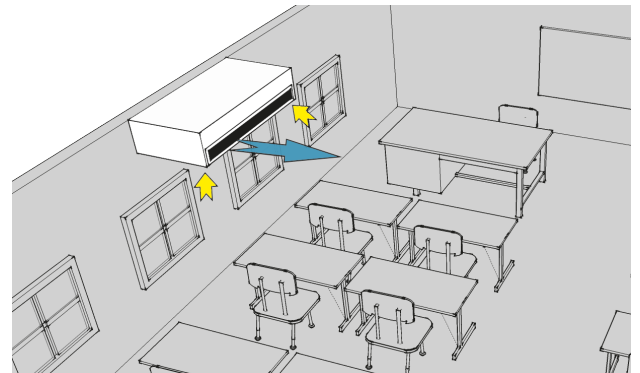
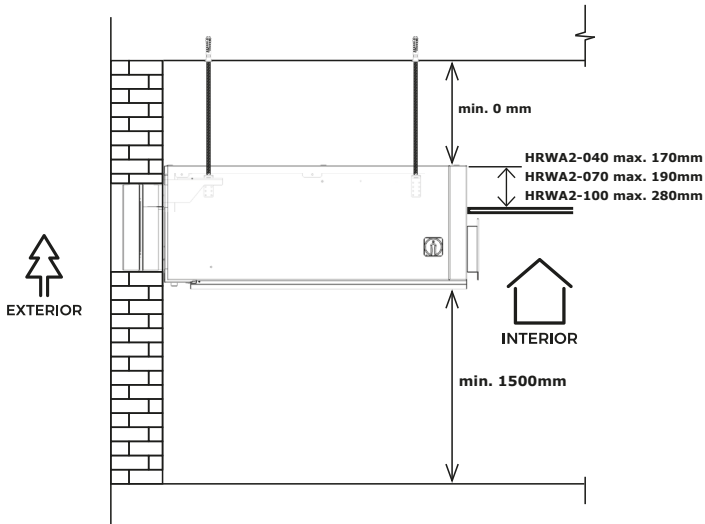



DIMENSIONS

STANDARD

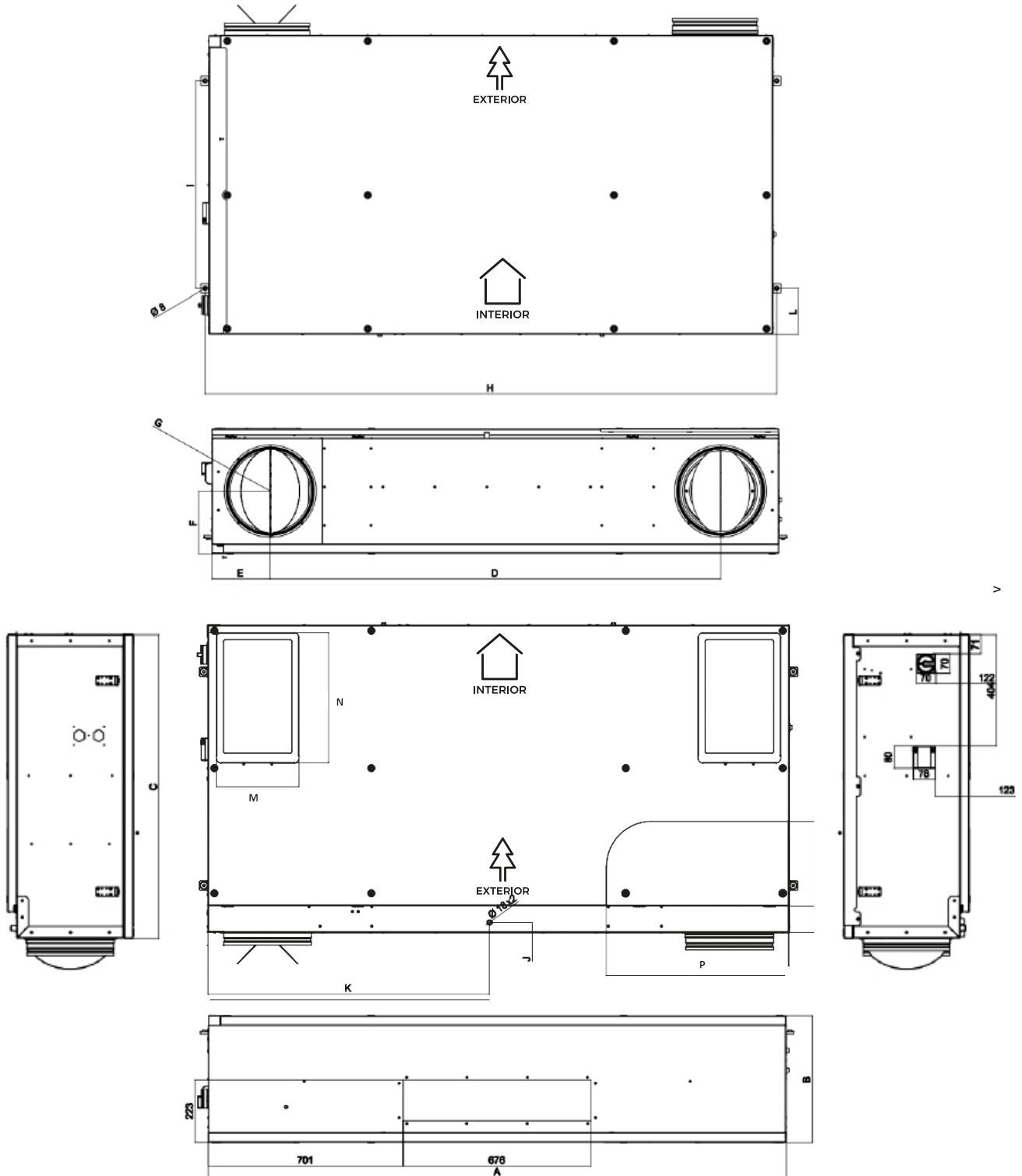

Type	[mm]																							
	A	B	C	D	E	F	G	H	I	J	K	L	M	N	O	P	Q	R	S	T	U	V	W	X
HRWA2-040	1806	398	940	1408	182	198	250	1835	689	32	875	143	265	446	875	600	212	90	145	558	686	384	53	70
HRWA2-070	2078	455	1098	1649	213	228	315	2105	763	37	1006	167	295	465	1006	650	302	94	223	701	676	404	71	123
HRWA2-100	2406	573	1262	1920	243	288	315	2435	962	31	1203	150	420	550	1203	625	303	104	243	642	1122	500	169	243



DIMENSIONS

DESIGN

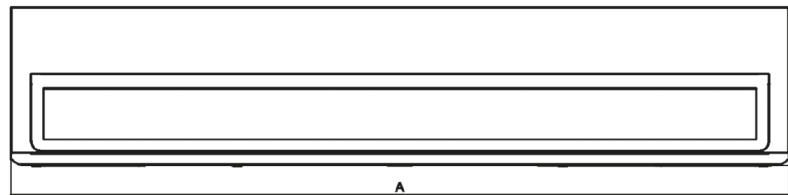
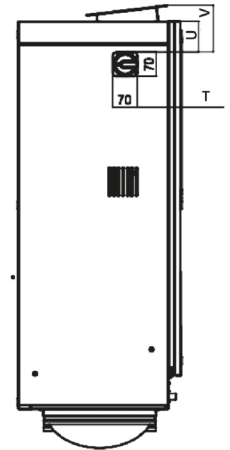
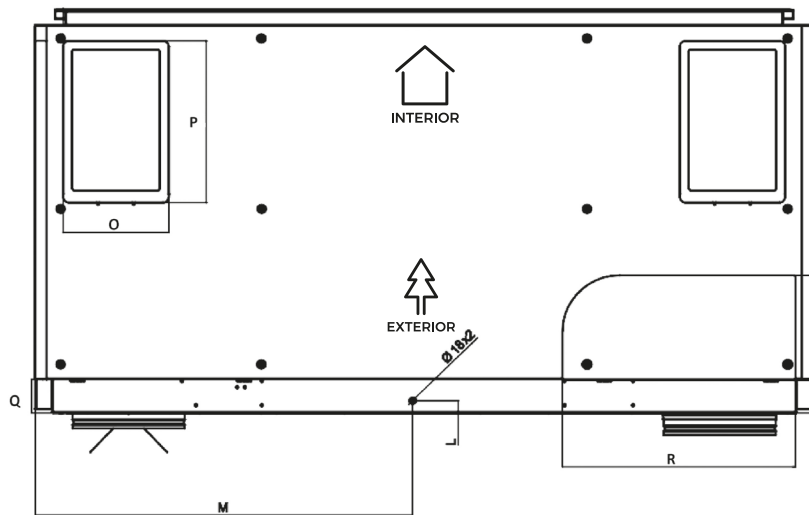
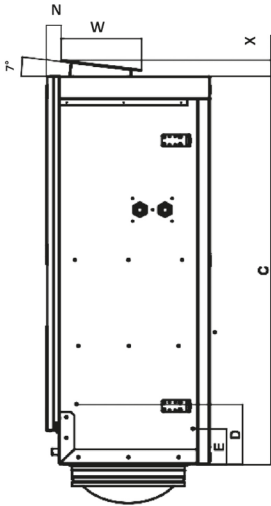
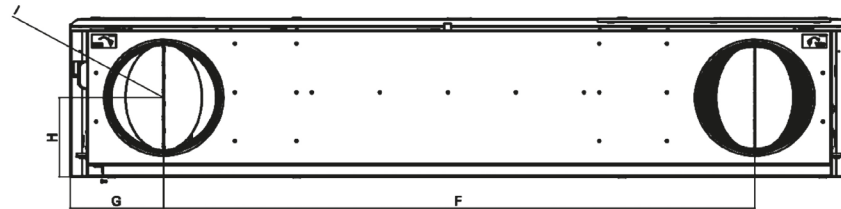
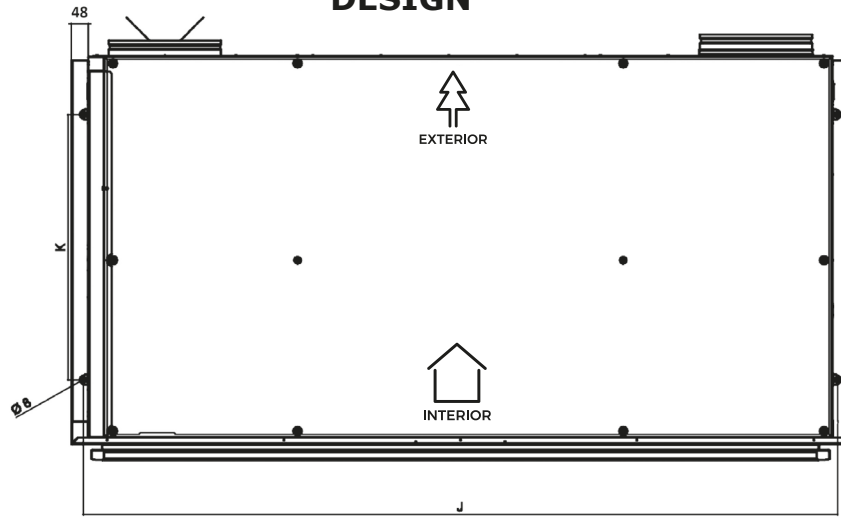

Type	[mm]																							
	A	B	C	D	E	F	G	H	I	J	K	L	M	N	O	P	Q	R	S	T	U	V	W	X
HRWA2-040	1901	397	963	195	165	1408	228	198	250	1835	689	32	922	45	265	446	88	600	212	70	74	120	179	46
HRWA2-070	2171	455	1116	172	102	1649	261	228	315	2105	763	37	1054	38	295	465	96	650	302	123	89	134	224	46
HRWA2-100	2501	575	1280	167	97	1920	291	288	315	2435	962	31	1251	64	420	550	104	625	303	244	184	230	224	46



DIMENSIONS

STANDARD UPPER

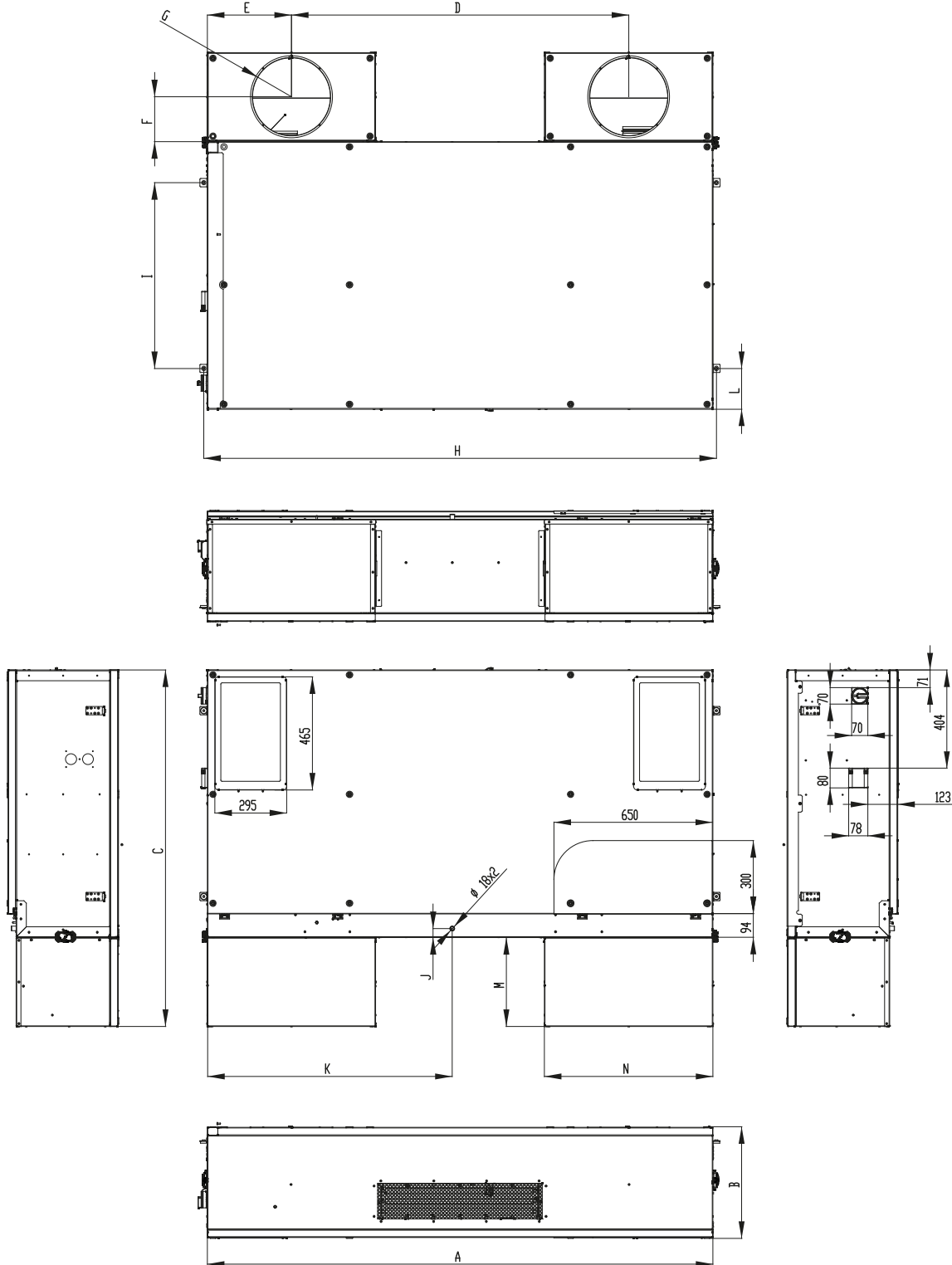

		[mm]													
Type	A	B	C	D	E	F	G	H	I	J	K	L	M	N	
HRWA2-040	1806	398	1242	1206	300	154	250	1835	689	32	875	143	302	600	
HRWA2-070	2078	455	1465	1385	393	185	315	2105	763	37	1006	167	365	695	
HRWA2-100	2406	573	1630	1605	400	186	315	2435	962	31	1203	150	367	802	



DIMENSIONS

DESIGN UPPER

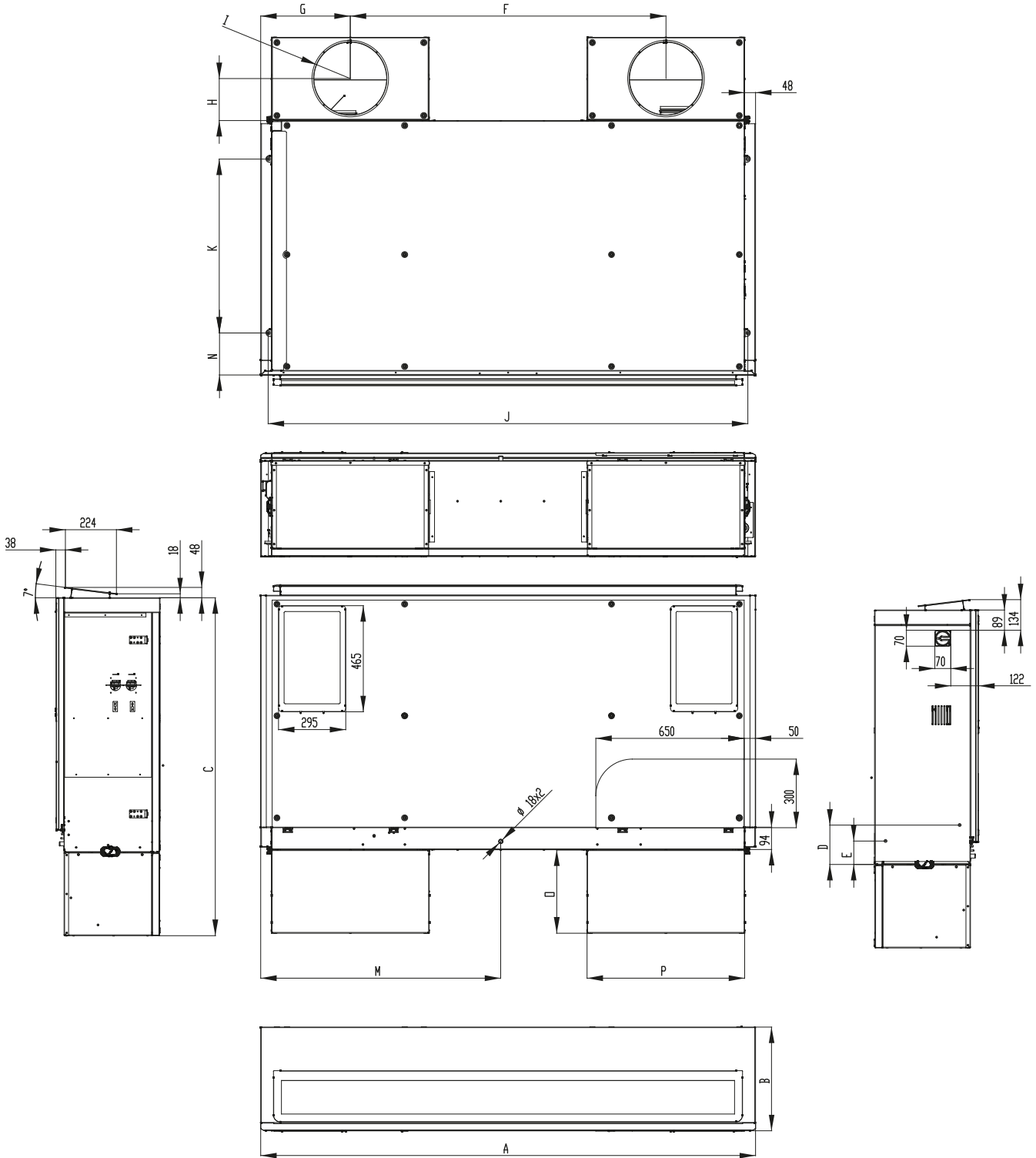

		[mm]														
Type	A	B	C	D	E	F	G	H	I	J	K	L	M	N	O	P
HRWA2-040	1901	397	1265	195	165	1206	338	154	250	1835	689	32	922	165.5	302	600
HRWA2-070	2171	455	1485	172	102	1385	393	188	315	2105	763	37	1054	185	365	695
HRWA2-100	2501	575	1647	167	97	1605	449	186	315	962	962	31	1251	169	367	802



CONTROL

AirGENIO SUPERIOR - Main control functions

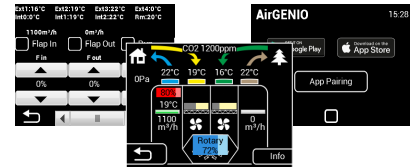
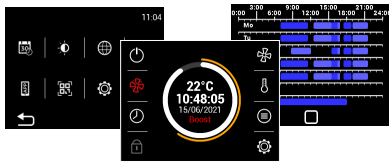

- Touch control
- Stepless fans (0-10V)
- Stepless afterheating (internal Electrical: SSR)
- Stepless automatic control of preheating
- Integrated timer (daily, weekly)
- Optional connection of sensors: CO2, RH, VOC (0-10)
- Stepless Bypass (temperature control: freecooling, antifreeze protection)
- Offset fan adjustment (over-pressure and underpressure)
- Indication of filter clogging
- CAV or DCV ventilation mode
- BOOST function - intensive airflow (nominal airflow +25%) for a set period
- Freecooling functions - night ventilation (cooling)
- Occupancy functions - reducing ventilation according to the PIR sensor
- BMS - connection via Modbus RTU / TCP, BACnet

2V AirGENIO Application:

- Product control on your smartphone
- Info about operation status
- Notifications – request for service, filter exchange, error status, etc.
- Download the 2V AirGENIO APP and control it remotely from your smart phone!



2V Service software:

- Easy and quick commissioning from your computer
- Error log – error display and identification
- Easy service (device status loading/reset to backup setting)
- Fast FW update
- OFFLINE version





WIRING DIAGRAMS

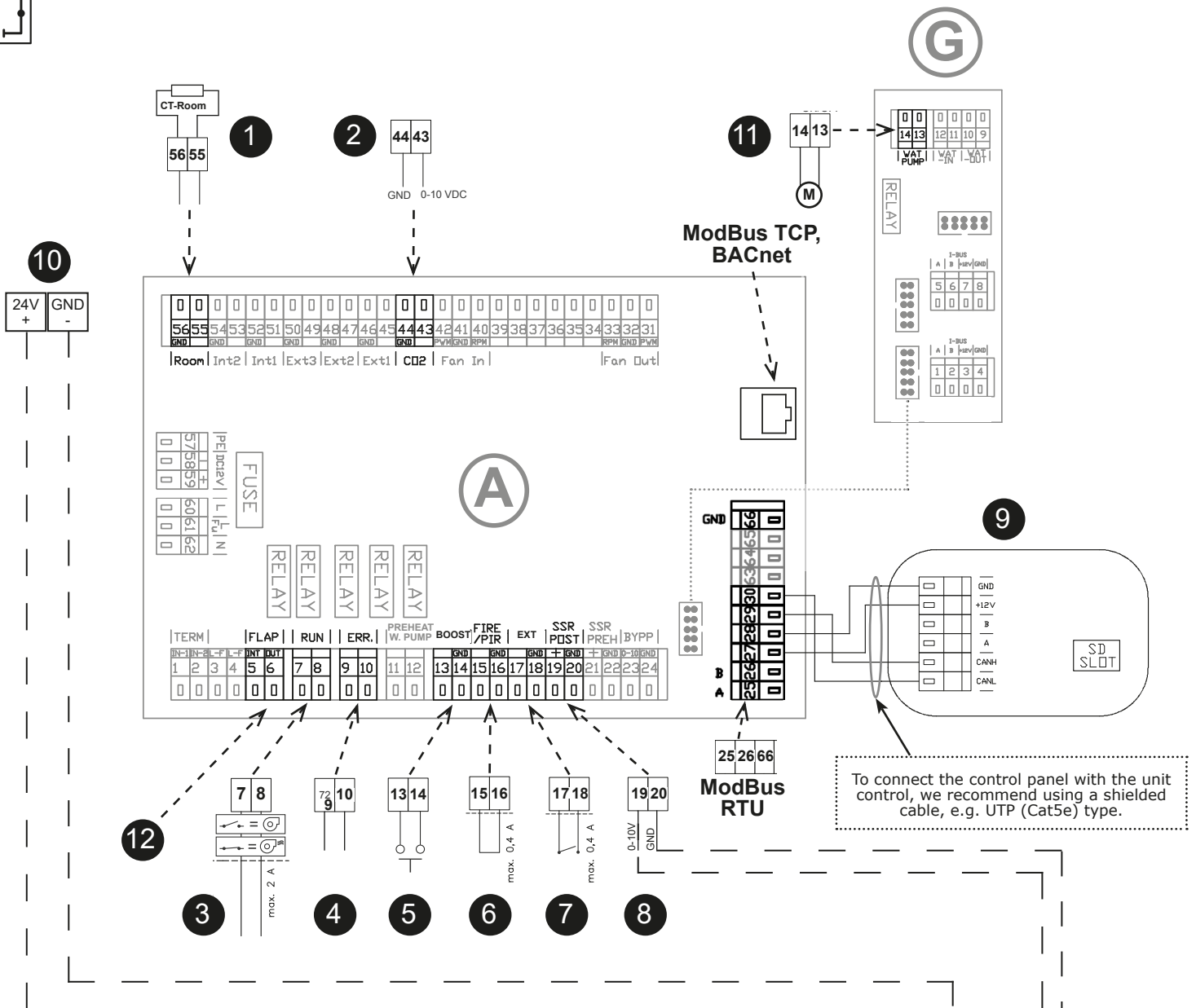

To connect the control panel with the unit control, we recommend using a shielded cable, e.g. UTP (Cat5e) type.

EN	
1	Room temperature sensor (input)
2	The air quality sensor - control signal (input)
3	RUN contact (relay contact)
4	ERROR contact (relay contact)
5	BOOST regime (input)
6	Alarm - FIRE (input) or PIR (input)
7	External control - ON/OFF
8	SMU control signal (0-10V, output)
9	Control panel
10	24V power supply for SMU (output)
11	Water pump (relay contact, max. 2A)
12	Air dampers (230V output - air IN/OUT)

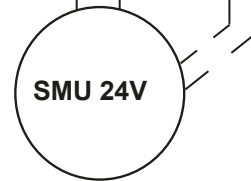



ACCESSORIES

RECOMMENDED ACCESSORIES

Filter replacement

Spare filters classes and configurations.



Unit type	Filter Coarse 60%	Filter ePM 10 60%	Filter ePM 1 60%
HRWA2-040	FILTR-HRWA1-040-G4	FILTR-HRWA1-040-M5	FILTR-HRWA1-040-F7
HRWA2-070	FILTR-HRWA1-070-G4	FILTR-HRWA1-070-M5	FILTR-HRWA1-070-F7
HRWA2-100	FILTR-HRWA1-100-G4	FILTR-HRWA1-100-M5	FILTR-HRWA1-100-F7

Condensate siphon

SK-HL138

Siphon with a ball for installation on the wall or flush mounting.



Condensate siphon

SK-AKS3

Ball Siphon for direct connection to the unit.



Condensate pump

SET-ASPEN-MAXI-ORANGE

Pump is designed to be installed in false ceilings.

Note:

Use of pump is recommended where gravity assisted condensate collection is not achievable.

Accessory supplied loose for fitting on site.

Pipework from pump not included.



PIR sensor

CI-PS 1003

Infrared room sensor for automatic ventilation based on presence of people in the ventilated area.



Module for connection from the top

Additional module to connect the air duct from the top.

Unit type	Module type	Module weight [kg]
HRWA2-040	HRWA2-040-UP-250	5,5
HRWA2-070	HRWA2-070-UP-315	7,1
HRWA2-100	HRWA2-100-UP-315	9,2

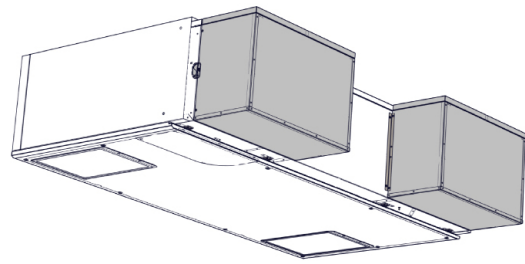

HRWA2 - 040 - UP - 250

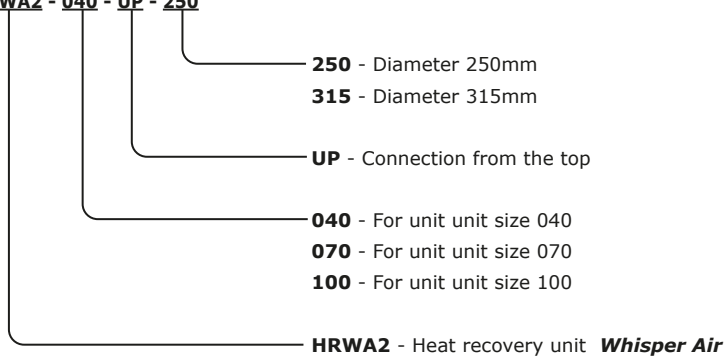

Threaded rods

ZTZ-M8-1,0 – threaded rod, thread M8, length 1m, suitable for all types of under the ceiling type units.



Wall holder

HRWA2-WALL-HOLDER (set 2 pcs.)

Anchoring the unit to the wall.



Air damper with actuator

KRTK-A-SB

Unit type	Air damper type
HRWA2-040	KRTK-A-250-SB
HRWA2-070	KRTK-A-315-SB
HRWA2-100	KRTK-A-315-SB



Air stream operated shutter

VK

Non-corrosive, long life, weather and ultra-violet stable polymers. Colour light grey. Easy and quick installation. Can be used as outlet shutter only.

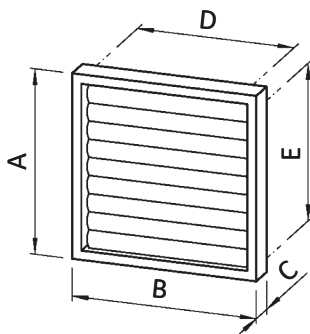

Unit type	Model	A [mm]	B [mm]	C [mm]	D [mm]	E [mm]
HRWA2-040	VK250	290	290	28	243	217
HRWA2-070	VK315	340	340	28	293	267
HRWA2-100	VK315	340	340	28	293	267

Air shutter with fixed lamelas

WFK

Non-corrosive, long life, weather and ultra-violet stable polymers. Colour light grey. Easy and quick installation. Can be used as inlet or outlet shutter.

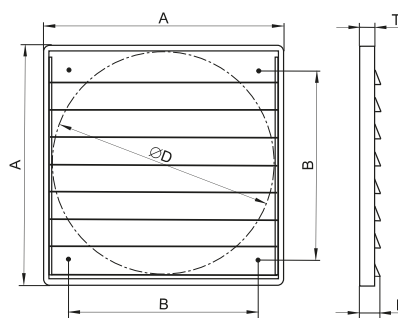

Unit type	Model	A [mm]	B [mm]	D [mm]	F [mm]	T [mm]
HRWA2-040	WFK-25-02	294	232	258	42	26
HRWA2-070	WFK-30-02	346	276	310	42	26
HRWA2-100	WFK-30-02	346	276	310	42	26



KEY TO CODING

HRWA2-070 HX CB E 74-E S0 C-0 A 0

